

NUOVA VASCA TURBO HIGH SPEED 3D - 105 LT.

Caratteristiche principali: nuova vasca speciale **High Speed 3D** per lavorazioni ad alto rendimento, brillantatura a sfere, abrasioni forti ad effetto tridimensionale applicata nella versione singola con ribaltamento ad azionamento oleodinamico, a richiesta viene fornito il motosetaccio o setaccio manuale per la separazione dei pezzi dall'abrasivo.

NEW TURBO TANK HIGH SPEED 3D - LITER 105

Main features: New special tank **High Speed 3D** for fast processing, ballburnishing, hard deburring three-dimensional effect applied on the single version, automatic discharge, motor or manual separation sieve upon request.

NEUER HIGH SPEED 3D-BEHÄLTER - 105 LT

Wichtigste eigenschaften: neue spezielle Bad **High Speed 3D**-Bearbeitung High-Performance-, Kugel-Polieren, Abrieb starken dreidimensionalen Effekt, Einfach-Ausführung mit Hydraulisch angetriebene Kippvorrichtung, Bei Bedarf mit automatischem oder manuellem Separiersieb für die Trennung der Steine und Teile.

NOUVEAU CUVE TURBO HIGH SPEED 3D-105 LT

Caractéristiques principales: nouveau cuve spécial **High Speed 3D** pour exécution à rendement élevé, brillantage à billes, fortes abrasions à effet tridimensionnel appliquée dans la version simple avec dispositif d'inclinaison hydraulique, sur demande avec module de séparation automatique ou manuel.



OPTIONAL

OPTIONAL:

Moto setaccio.
 Motor separation sieve.
 Motorräder Sieve.
 Tamiser motos.

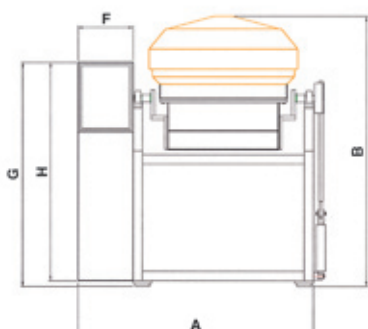
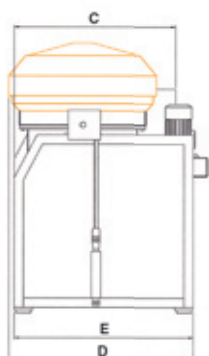
TECHNICAL DETAILS
Mod.: 105 lt.

• A	1280
• B	1447
• C	884
• D	1009
• E	980
• F	300
• G	1200
• H	1170
• LAVORO MAX / MAX CAPACITY INSIDE MAX ARBEITSKAPAZITÄT / CAPACITÉ MAX. DE TRAVAIL:	30-40 kg
• MOTORE / MOTOR / MOTOR / MOTEUR:	1-1.5 kw
• PESO / WEIGHT / GEWICHT / POIDS:	215-235 kg