

PSA Oxygen Generator

AS-B



AirSep Alpha-Series Oxygen Generators produce from 20 to 5,000 cubic feet of oxygen per hour at up to 95.5% oxygen concentration. When electricity and a source of compressed air is supplied, these dependable machines can provide oxygen for any application.

Features

- Produces oxygen from an independent compressed air source
- Microprocessor controlled
- Low operating cost
- Automatic and unattended operation
- Easy to install and maintain

Typical Applications

Manufacturing

- Cutting/Brazing/Soldering
- Thermal/Chemical Oxidation

Medical

- Hospital Systems

Environmental

- Ozone (Generator) Feed Gas
- Environmental Remediation
- Waste/Water Treatment

Glass Industry

- Glass Work/Manufacturing/Blowing

Additional

- Fish Farming

Specifications

AS-B

Product Characteristics	
Product Flow	45 - 55 SCFH (1.18 - 1.45 Nm ³ /hr) ¹
Product Pressure	45-55 psig (310-379 kPa) ¹
Product Concentration (nominal)	93%
Product Dew Point	-100°F (-73°C)
Dimensions (W x D x H) (nominal)	17 x 15 x 58 in (43 x 38 x 147 cm)
Weight	246 lb (112 kg)
Physical Connections ²	
Compressed Air Inlet	¼" FNPT
Product Gas Outlet	¼" FNPT
Ambient Operating Conditions	Locate the oxygen generator in a well-ventilated area that is protected from weather elements and remains between 40°F (4°C) and 104°F (40°C)
Feed Air Requirements	Flow Rate: <i>Refer to chart on reverse page.</i> Clean and Dry "Plant Air" (Class 5.6.5 per ISO 8573.1) Pressure: 90 psig (621 kPa) minimum Temperature: 122°F (50°C) maximum
Control Power Requirements (Single Phase)	120 V ~ ±10%, 50/60 Hz, 1.0 A or 240 V ~ ±10%, 50/60 Hz, 0.5 A
60 Gallon Oxygen Receiver Characteristics	
Dimensions (Dia. x H)	26 x 52 in (65 x 131 cm)
Weight	159 lb (72 kg)

¹ SCF (Standard cubic foot) gas measured at 1 atmosphere and 70°F / Nm³ (Normal cubic meter) gas measured at 1 atmosphere and 0°C

² Hose and applicable adapters included with optional factory supplied accessory kits.

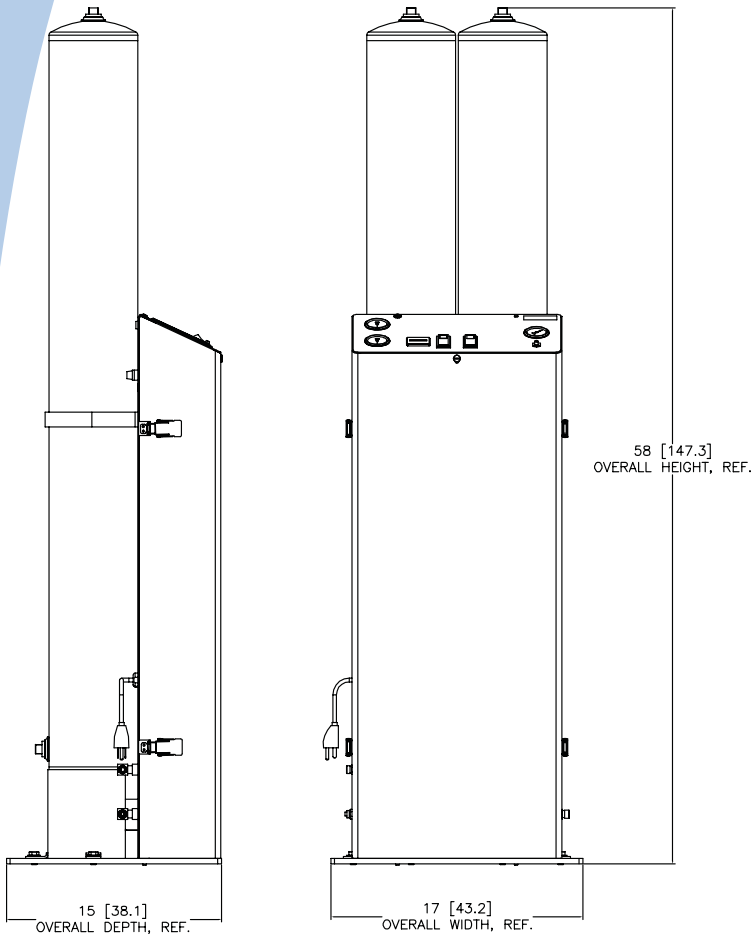

Note: All dimensions are nominal.

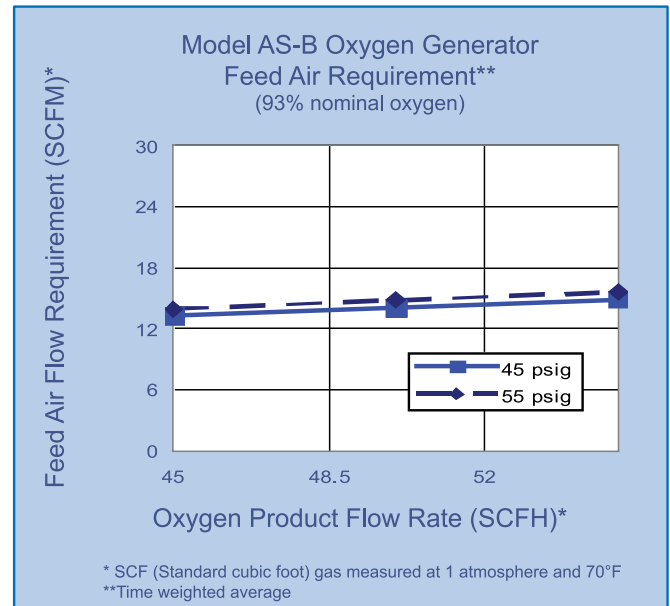

Ordering Information

Model	Part Number	Description	
AS-B	AS101-1	120 V ~ ±10%, 50/60 Hz ¹	
	AS101-2	240 V ~ ±10%, 50/60 Hz ¹	
Accessories	TA150-1	60 Gallon Oxygen Receiver	
	KI410-1	Accessory Kit (interconnecting hoses/fittings and oxygen regulator)	
	KI474-1	Accessory Kit (oxygen hose - oxygen regulator to use point)	
	KI404-1	Accessory Kit (mini manifold)	
Shipping Information		AS-B	60 Gallon Oxygen Receiver
Class		92.5	70
Commodity Classification Number		8421.39.8040	7311.00.0000
Dimensions (W x D x H)		24 x 65 x 23 in (61 x 165 x 58 cm) with Accessory Kit(s), Boxed 29 x 69 x 25 in (74 x 175 x 64 cm) with Accessory Kit(s), Crated 25x 65 x 24 in (64 x 165 x 61 cm) with Accessory Kit(s) and CE Beds, Crated	28 x 30 x 56 in (71 x 76 x 142 cm)
Gross Weight		295 lb (134 kg) with Accessory Kit(s), Boxed 378 lb (171 kg) with Accessory Kit(s), Crated 328 lb (149 kg) with Accessory Kit(s) and CE Beds, Crated	177 lb (80 kg)

Warranty: 1 Year Parts and Factory Labor***

*** An unprotected or inadequately ventilated environment, or improper control power may cause damage to the oxygen generator not covered under warranty.

¹ Specify oxygen flow and pressure at time of order.

All performance ratings based on an ambient temperature up to 100°F (38°C), up to 1,000 feet elevation, and 80% relative humidity.