



made in Italy



DISOLIATURA

DISOLIATRICE AUTOMATICA CON CARICO E SCARICO AUTOMATICO

Viene impiegata per la disoliatura di minuterie metalliche, prodotte in continuo dalle stampatrici.

Il carico viene effettuato su nastro trasportatore, lo scarico mediante rovesciamento del cesto.

Carico e scarico automatici.

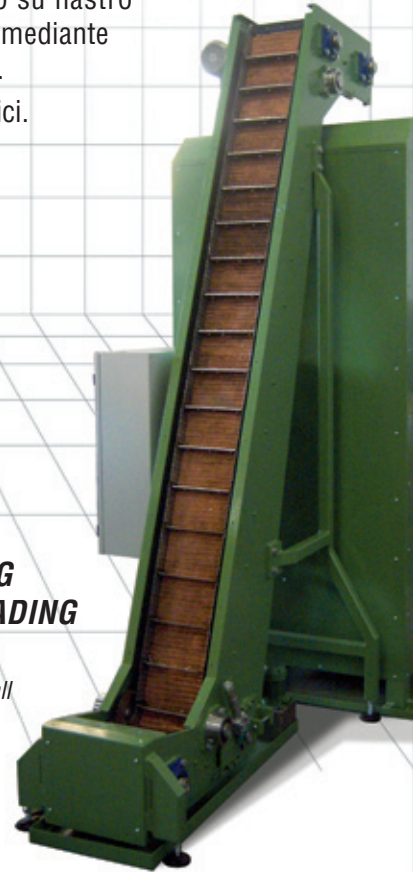

AUTOMATIC DE-OILING WITH AUTOMATIC LOADING AND UNLOADING

It is used for de-oiling small metal, produced continuously by printing presses.

The load is carried on a conveyor belt, the discharge by tipping the basket.

Automatic loading and unloading.

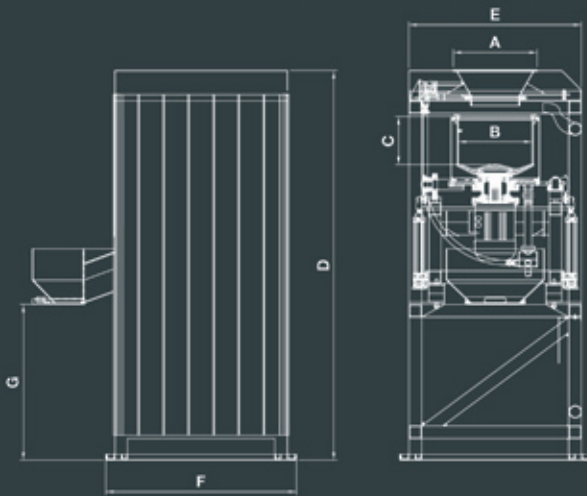

CARATTERISTICHE TECNICHE: TECHNICAL DETAILS:

Mod.	270	480
• A	350	530
• B	270	470
• C	200	300
• D	1460	2490
• E	700	1100
• F	800	1220
• G	300	1000
• MOTORE / MOTOR:	0.75 kw	3 kw
• GIRI / R.P.M.:	900	900
• PESO / WEIGHT:	300 kg	- kg

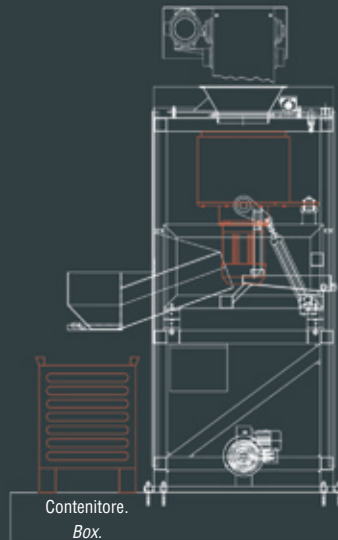

Contentitore.
Box.

Esempi di applicazioni delle nostre macchine:

Applications
of our machines:

